

# 0-10VDC linear control wiring

Recommendation for use with external controller

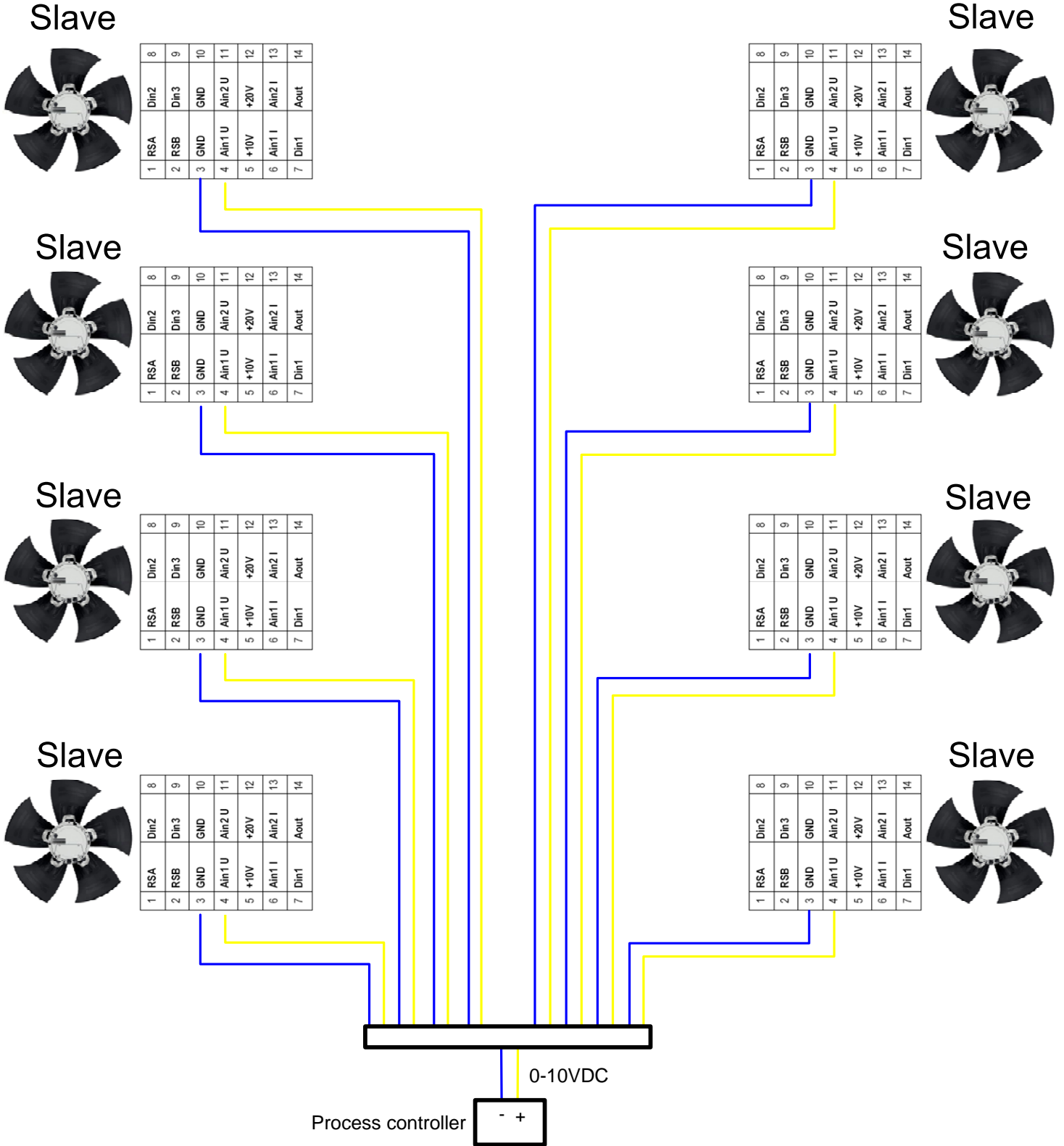

# 0-10VDC linear control wiring

Optional override for manual operation or emergency mode

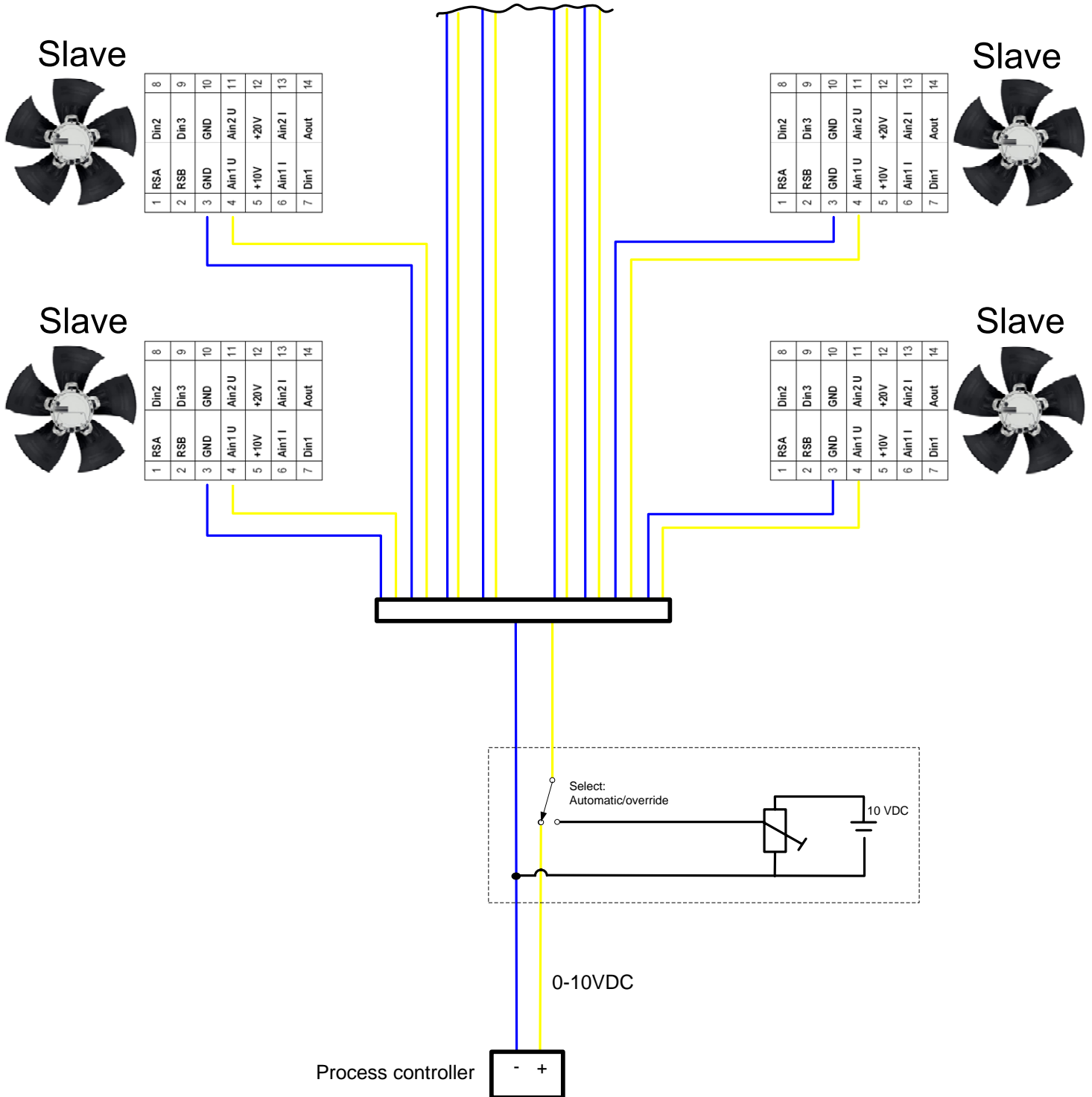

# Linear control wiring

Recommendation for use with a master fan and one 4-20mA sensor

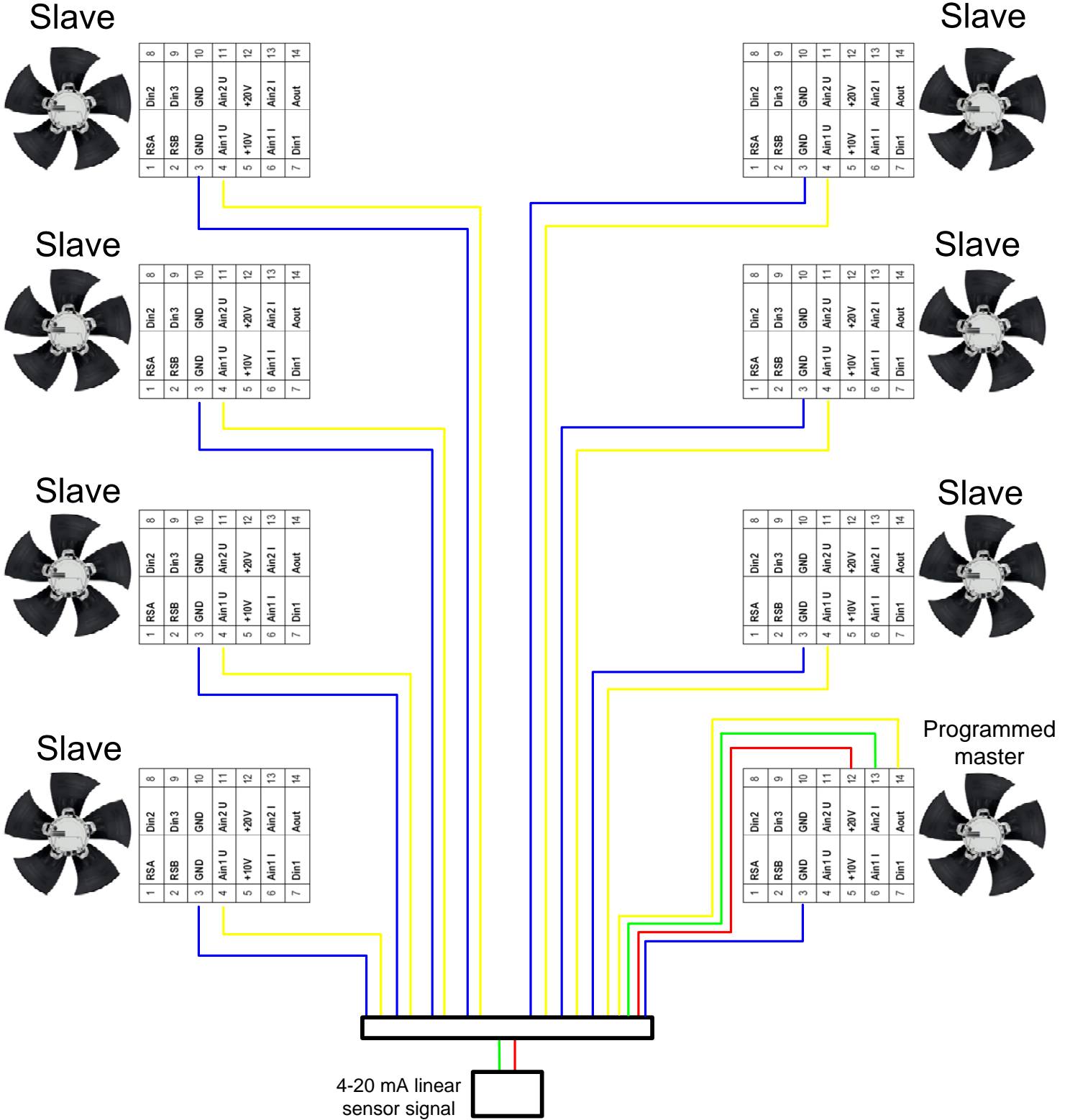

# RS485 bus wiring recommendation

Address group 1, fan 7



1	RSA	Din2	8
2	RSB	Din3	9
3	GND	GND	10
4	Ain1 U	Ain2 U	11
5	+10V	+20V	12
6	Ain1 I	Ain2 I	13
7	Din1	Aout	14

Address group 1, fan 8



1	RSA	Din2	8
2	RSB	Din3	9
3	GND	GND	10
4	Ain1 U	Ain2 U	11
5	+10V	+20V	12
6	Ain1 I	Ain2 I	13
7	Din1	Aout	14

Address group 1, fan 5



1	RSA	Din2	8
2	RSB	Din3	9
3	GND	GND	10
4	Ain1 U	Ain2 U	11
5	+10V	+20V	12
6	Ain1 I	Ain2 I	13
7	Din1	Aout	14

Address group 1, fan 6



1	RSA	Din2	8
2	RSB	Din3	9
3	GND	GND	10
4	Ain1 U	Ain2 U	11
5	+10V	+20V	12
6	Ain1 I	Ain2 I	13
7	Din1	Aout	14

Address group 1, fan 3



1	RSA	Din2	8
2	RSB	Din3	9
3	GND	GND	10
4	Ain1 U	Ain2 U	11
5	+10V	+20V	12
6	Ain1 I	Ain2 I	13
7	Din1	Aout	14

Address group 1, fan 4



1	RSA	Din2	8
2	RSB	Din3	9
3	GND	GND	10
4	Ain1 U	Ain2 U	11
5	+10V	+20V	12
6	Ain1 I	Ain2 I	13
7	Din1	Aout	14

Address group 1, fan 1



1	RSA	Din2	8
2	RSB	Din3	9
3	GND	GND	10
4	Ain1 U	Ain2 U	11
5	+10V	+20V	12
6	Ain1 I	Ain2 I	13
7	Din1	Aout	14

Address group 1, fan 2



1	RSA	Din2	8
2	RSB	Din3	9
3	GND	GND	10
4	Ain1 U	Ain2 U	11
5	+10V	+20V	12
6	Ain1 I	Ain2 I	13
7	Din1	Aout	14



RS485 interface  
from RS232  
or  
from Bluetooth®



OR

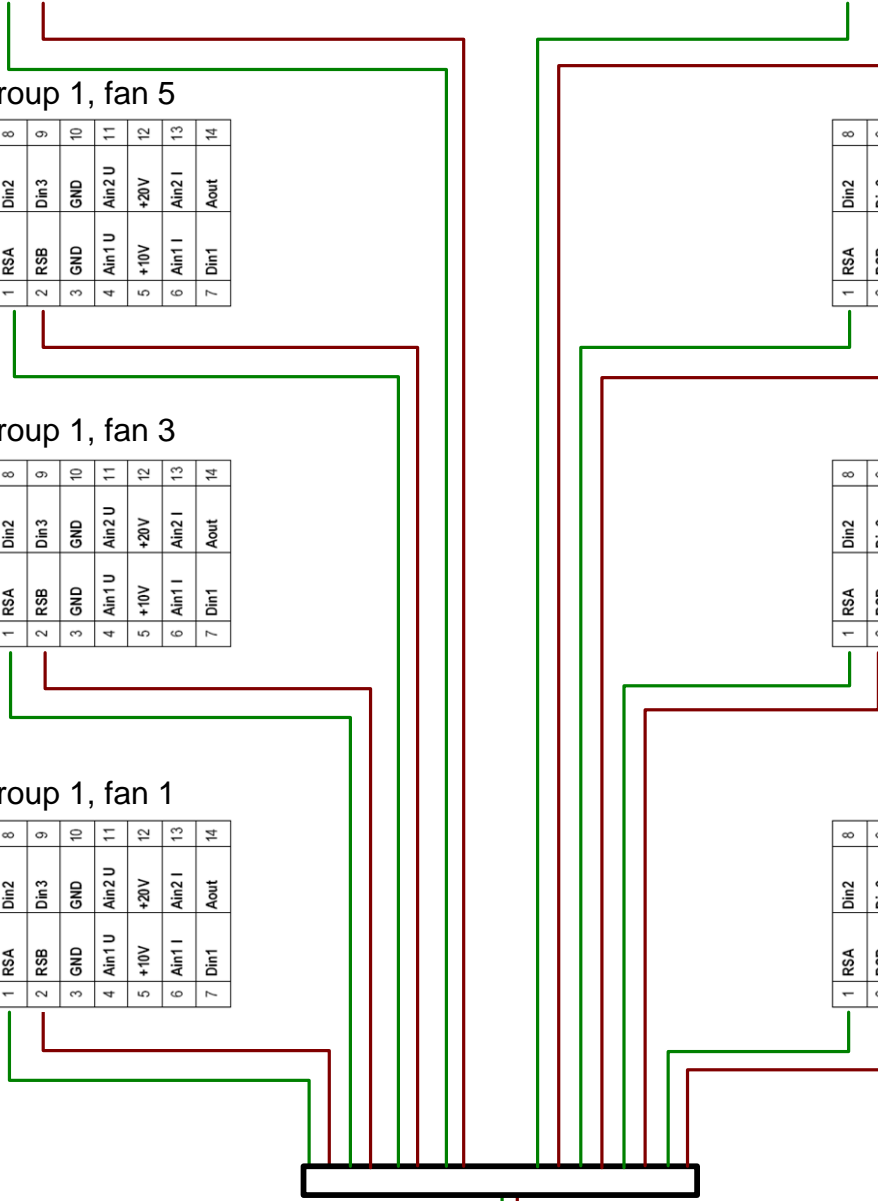

# Alarm wiring recommendation

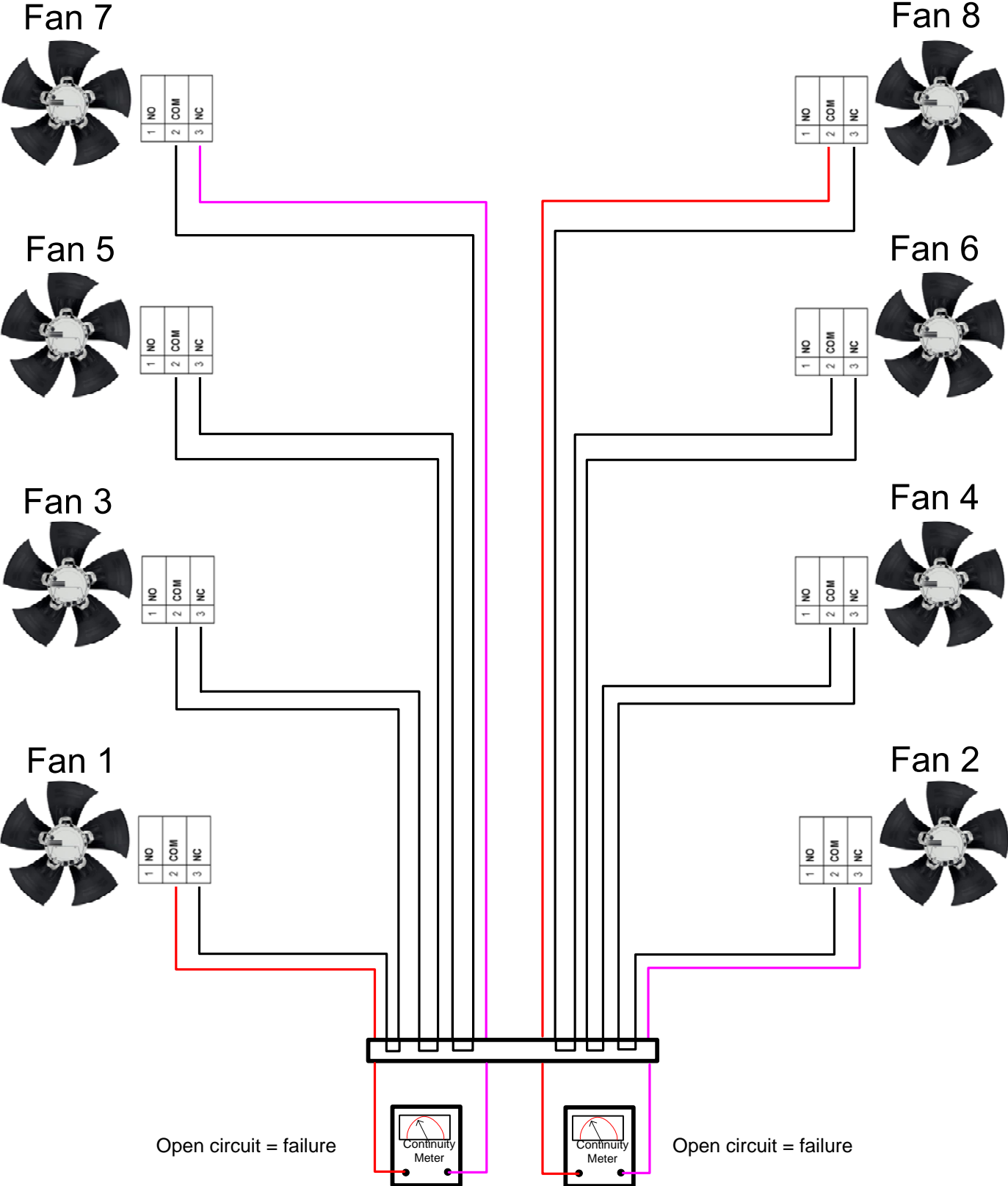

	<b>0-10VDC linear control wiring</b> Recommendation for use with external controller	<b>0-10VDC linear control wiring</b> Optional override for manual operation or emergency mode	<b>Linear control wiring</b> Recommendation for use with a master fan and one 4-20mA sensor	<b>RS485 bus wiring recommendation</b>	<b>Alarm wiring recommendation</b>
Function	<ul style="list-style-type: none"> <li>• Closed loop process control using an external master</li> <li>• All EC fans are modulating from 100% to 10% or off</li> </ul>	<ul style="list-style-type: none"> <li>• Closed loop process control using an external master</li> <li>• All EC fans are modulating from 100% to 10% or off</li> <li>• The process controller signal can be bypassed for service or for emergency operation</li> </ul>	<ul style="list-style-type: none"> <li>• Closed loop process control without external master</li> <li>• All EC fans are modulating from 100% to 10% or off</li> </ul>	<ul style="list-style-type: none"> <li>• Direct digital control (DDC)</li> </ul>	<ul style="list-style-type: none"> <li>• Detects any fan failure and any motor supply voltage failure</li> <li>• Note - a short in the alarm wiring would not be detected</li> </ul>
Benefit	<ul style="list-style-type: none"> <li>• External process controller (= external master) are available for complex controls and communication functions</li> </ul>	<ul style="list-style-type: none"> <li>• Simple manual intervention for abnormal conditions</li> <li>• If used with an automatic switch it provides an option for redundancy</li> </ul>	<ul style="list-style-type: none"> <li>• Simple load matching</li> <li>• No external controller needed</li> <li>• Stand alone system</li> <li>• All slaves use factory default settings</li> <li>• Straight-forward system</li> <li>• Easy troubleshooting</li> <li>• Can be combined with optional override</li> </ul>	<ul style="list-style-type: none"> <li>• Comprehensive diagnosis + control</li> </ul>	<ul style="list-style-type: none"> <li>• Simple/straight forward</li> <li>• Universal dry contact output for optional integration into other systems at low cost</li> <li>• Provides early warning for service request</li> <li>• Low cost option for use with a buzzer or warning light</li> </ul>
Requirements	<ul style="list-style-type: none"> <li>• External process controller with 0-10VDC linear output</li> <li>• Additional requirements for redundancy</li> </ul>	<ul style="list-style-type: none"> <li>• Separate 10VDC power supply for independent operation</li> </ul>	<ul style="list-style-type: none"> <li>• Master adjusted or programmed from factory default to process-specific* settings</li> <li>• Setpoint signal* (programmed setpoint or L5 interface with linear setpoint signal)</li> <li>• Additional requirements for redundancy</li> </ul>	<ul style="list-style-type: none"> <li>• Device with Microsoft® Windows® 2000 or XP Windows Mobile 5, 6, 6.1® or gateway</li> <li>• ebm-papst software or equivalent</li> <li>• Twisted pair cables</li> <li>• Each EC motor has a unique address, programmed by the equipment manufacturers</li> </ul>	<ul style="list-style-type: none"> <li>• Daisy-chained motor alarm outputs</li> <li>• Circuit monitoring with an external device</li> </ul>

\*Refer to accessories list for necessary programming hardware and software