

EC axial fans

S-Range, Ø 910

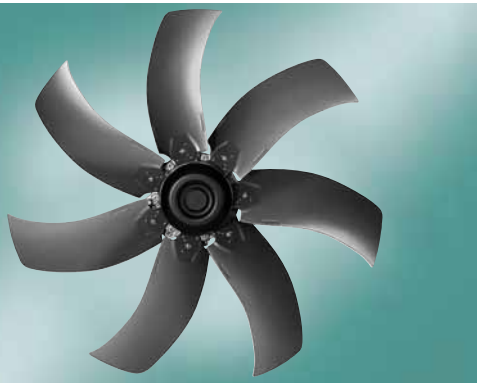

- **Material:** stator and electronics housing made of die-cast aluminium, rotor made of sheet steel (black, KTL coated), impeller blades made of die-cast aluminium
- **Technical features:** control input 0-10 VDC / PWM, RS485 eBUS, alarm relay, integrated PID control, voltage supply for sensor, input for sensor 0-10 V respectively 4-20 mA, 0-10 V output for slave, PFC (passive), soft start, line undervoltage detection, phase failure detection, motor current limitation, over-temperature protected electronics and motor, locked-rotor protection
- **Type of protection:** IP 54 according to DIN VDE 0470, part 1 (EN 60 529) category 2
- **Insulation class:** "F"
- **Approvals:** UL, CE and GOST; with 380-480 VAC with VDE; CCC is planned

ebm-papst • Muldingen

Nominal data⁽¹⁾

Type	Motor	Characteristic	Nominal voltage range	Frequency	Speed/rpm	Max. power input ⁽²⁾	Max. current draw ⁽²⁾	Max. back pressure	Perm. amb. temp.	Mass A3G...	Mass S3G...	Mass W3G...
Type	Motor	VAC	Hz	min ⁻¹	kW	A	Pa	°C	kg	kg	kg	
*3G 910	M3G150-FF	① 200-240	50/60	650	1,00	3,7	90	-25..+60	26,0	35,0	51,0	
	M3G150-FF	② 380-480	50/60	650	1,00	1,7	90	-25..+60	26,0	35,0	51,0	

subject to alterations

⁽¹⁾ at 230 resp. 400 VAC

⁽²⁾ in operating point with maximum load

	n	P ₁	I	Lp _A	η _{HL}		n	P ₁	I	Lp _A	η _{HL}
	[min ⁻¹]	[kW]	[A]	[dBA]	[%]		[min ⁻¹]	[kW]	[A]	[dBA]	[%]
① ①	650	0,76	2,8	70	79	① ⑨	450	0,26	1,0	62	79
① ②	650	0,93	3,2	72	73	① ⑩	450	0,32	1,2	64	73
① ③	650	0,99	3,4	73	67	① ⑪	450	0,34	1,4	64	67
① ④	650	1,01	3,4	73	64	① ⑫	450	0,35	1,4	65	64
① ⑤	540	0,44	1,6	66	79						
① ⑥	540	0,53	2,0	68	73						
① ⑦	540	0,57	2,2	69	67						
① ⑧	540	0,58	2,2	69	64						

	n	P ₁	I	Lp _A	η _{HL}		n	P ₁	I	Lp _A	η _{HL}
	[min ⁻¹]	[kW]	[A]	[dBA]	[%]		[min ⁻¹]	[kW]	[A]	[dBA]	[%]
② ①	650	0,76	1,4	70	79	② ⑨	450	0,26	0,5	62	79
② ②	650	0,93	1,6	72	73	② ⑩	450	0,32	0,6	64	73
② ③	650	0,99	1,7	73	67	② ⑪	450	0,34	0,7	64	67
② ④	650	1,01	1,7	73	64	② ⑫	450	0,35	0,7	65	64
② ⑤	540	0,44	0,8	66	79						
② ⑥	540	0,53	1,0	68	73						
② ⑦	540	0,57	1,1	69	67						
② ⑧	540	0,58	1,1	69	64						

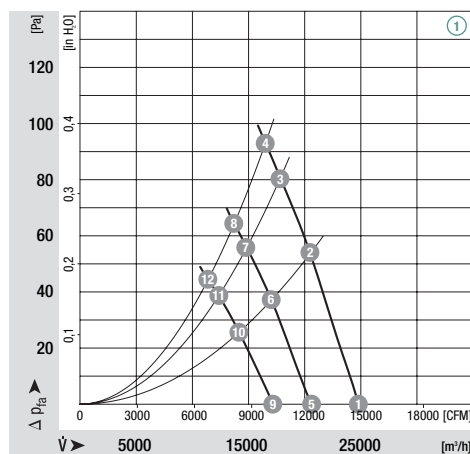

Characteristics

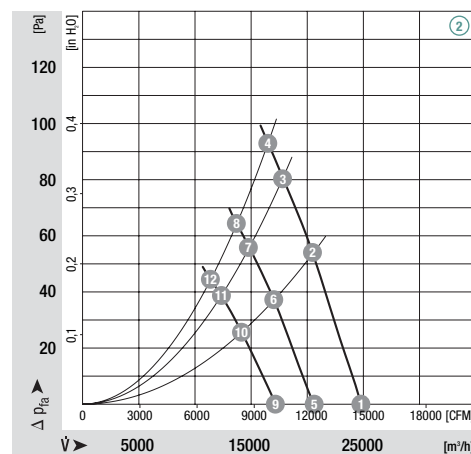

Characteristics



- **Mounting position / condensate discharges:** shaft horizontal or rotor at the bottom with condensate discharge(s) in the rotor, mounting position rotor on top on request

Selection	Cable exit	Direction of air flow	Direction of rotation				Dimensions
Type	S/A/B	R/L	R/L				d
*3G 910	S	"V"	R	A3G910-AC07 -13	S3G910-BC07 -13	W3G910-CC07 -13	219,5
		"A"	L	A3G910-AC07 -14	---	---	219,5
	S	"V"	R	A3G910-AC05 -03	S3G910-BC05 -03	W3G910-CC05 -03	219,5
		"A"	L	A3G910-AC05 -04	---	---	219,5

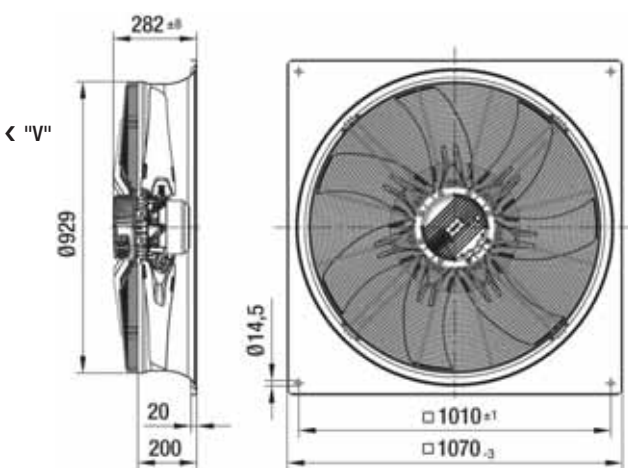
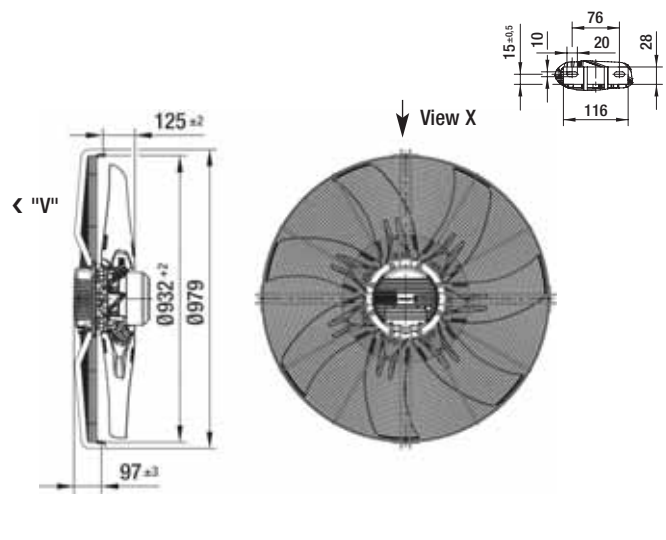
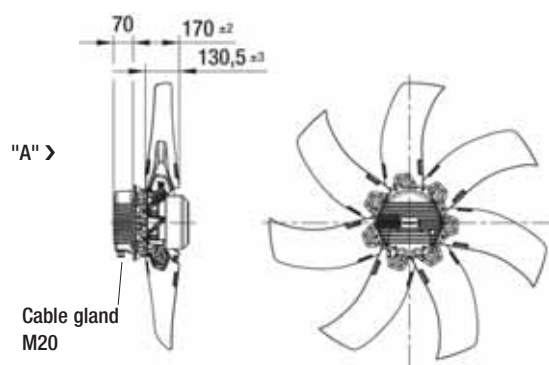
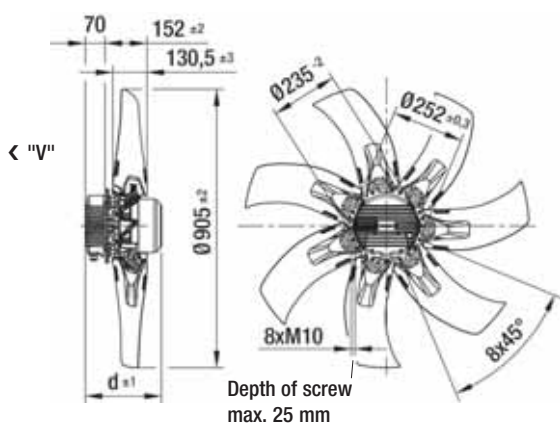

EC axial fans

S-Range, Ø 910

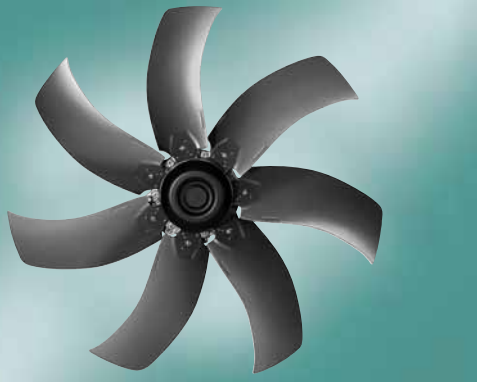

- **Material:** stator and electronics housing made of die-cast aluminium, rotor made of sheet steel (black, KTL coated), impeller blades made of die-cast aluminium
- **Technical features:** control input 0-10 VDC / PWM, RS485 ebmBUS, alarm relay, integrated PID control, voltage supply for sensor, input for sensor 0-10 V respectively 4-20 mA, 0-10 V output for slave, PFC (passive), soft start, line undervoltage detection, phase failure detection, motor current limitation, over-temperature protected electronics and motor, locked-rotor protection
- **Type of protection:** IP 54 according to DIN VDE 0470, part 1 (EN 60 529) category 2
- **Insulation class:** "F"
- **Approvals:** UL, CE and GOST; with 380-480 VAC with VDE; CCC is planned

ebm-papst • Muldingen

Nominal data ⁽¹⁾		Characteristic	Nominal voltage range	Frequency	Speed/rpm	Max. power input ⁽²⁾	Max. current draw ⁽²⁾	Max. back pressure	Perm. amb. temp.	Mass A3G...	Mass S3G...	Mass W3G...
Type	Motor	VAC	Hz	min ⁻¹	kW	A	Pa	°C	kg	kg	kg	
*3G 910	M3G150-IF	① 200-240	50/60	780	1,70	5,9	130	-25..+60	30,0	39,0	55,0	
	M3G150-IF	② 380-480	50/60	780	1,70	3,1	130	-25..+60	30,0	39,0	55,0	

subject to alterations

⁽¹⁾ at 230 resp. 400 VAC

⁽²⁾ in operating point with maximum load

	n [min ⁻¹]	P ₁ [kW]	I [A]	Lp _A [dBA]	η _{HL} [%]
① ①	780	1,30	4,4	76	79
① ②	780	1,59	5,2	77	73
① ③	780	1,70	5,4	78	67
① ④	780	1,73	5,6	79	64
① ⑤	650	0,78	2,8	70	79
① ⑥	650	0,95	3,2	72	73
① ⑦	650	1,02	3,4	73	67
① ⑧	650	1,03	3,6	73	64
① ⑨	540	0,47	1,8	66	79
① ⑩	540	0,57	2,2	68	73
① ⑪	540	0,61	2,2	69	67
① ⑫	540	0,62	2,2	69	64

	n [min ⁻¹]	P ₁ [kW]	I [A]	Lp _A [dBA]	η _{HL} [%]
② ①	780	1,30	2,2	76	79
② ②	780	1,59	2,6	77	73
② ③	780	1,70	2,7	78	67
② ④	780	1,73	2,8	79	64
② ⑤	650	0,78	1,4	70	79
② ⑥	650	0,95	1,6	72	73
② ⑦	650	1,02	1,7	73	67
② ⑧	650	1,03	1,8	73	64
② ⑨	540	0,47	0,9	66	79
② ⑩	540	0,57	1,1	68	73
② ⑪	540	0,61	1,1	69	67
② ⑫	540	0,62	1,1	69	64

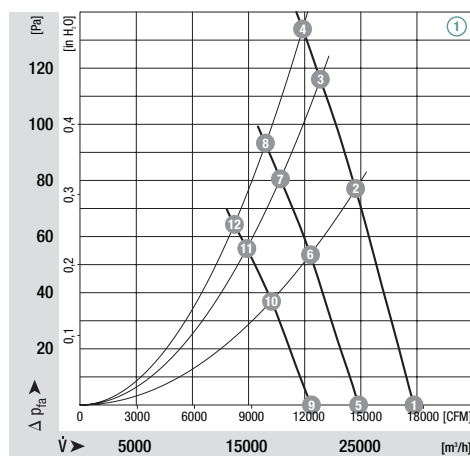

Characteristics

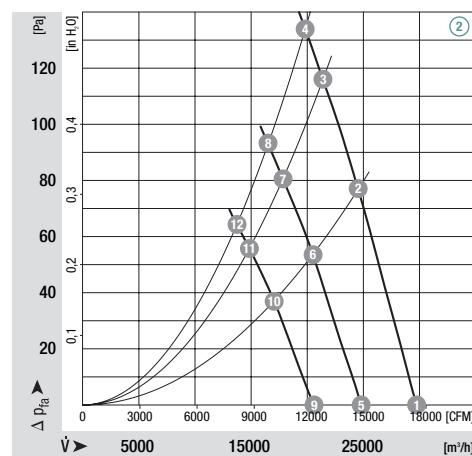

Characteristics



- **Mounting position / condensate discharges:** shaft horizontal or rotor at the bottom with condensate discharge(s) in the rotor, mounting position rotor on top on request

Selection	Cable exit	Direction of air flow	Direction of rotation				Dimensions
Type	S/A/B	R/L	R/L				d
*3G 910	S	"V"	R	A3G910-AD09 -13	S3G910-BD09 -13	W3G910-CD09 -13	249,5
		"A"	L	A3G910-AD09 -14	---	---	249,5
	S	"V"	R	A3G910-AD04 -03	S3G910-BD04 -03	W3G910-CD04 -03	249,5
		"A"	L	A3G910-AD04 -04	---	---	249,5

